

E-Z LUBE[®]

BEARING LUBRICATION SYSTEM

BEARING LUBRICATION MADE QUICK & EASY

- A trailer running gear lubrication system that's simple to maintain and completely submersible
- Allows grease to easily flow to both the inner and outer bearings for a complete repack
- No disassembly required, just attach a grease gun at the spindle end and inject the grease
- E-Z Lube[®] cap allows for easy access, extra protection, and virtually no mess
- Easily purges contaminated grease without removing the hub
- Ideal for most towable axles including boat trailer applications
- Five-year limited product warranty for sprung axles
- Ten-year limited product warranty for torsion axles

 **E-Z LUBE[®]**
BEARING LUBRICATION SYSTEM

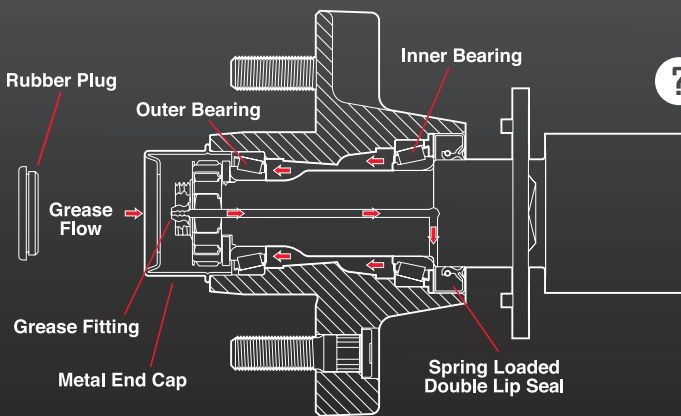
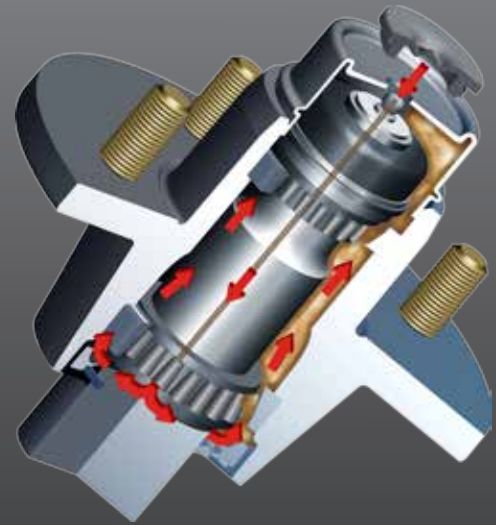

WHAT IS E-Z LUBE[®]?

The E-Z Lube[®] system consists of axle spindles that have been specially drilled and assembled with grease fittings. When grease is pumped into the fittings, it is channeled to the inner bearing, then to the outer bearing, and eventually back out the grease cap hole for a complete bearing repack. The protection and maintenance features of the E-Z Lube[®] system make it ideal for most towable axles. E-Z Lube[®] is designed to allow for immersion in water.

E-Z Lube[®] is subject to the maintenance and inspection procedures as specified in Dexter Axle's current publication, "Operation Maintenance Service Manual".

Scan to view
E-Z Lube[®] Video

