

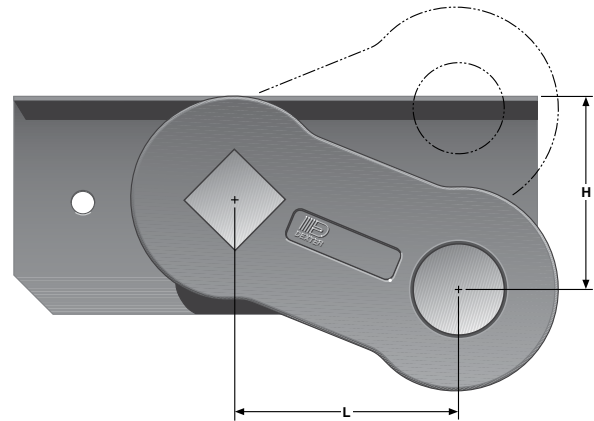

Articulation Dimensions

Dimensions are for high profile, top mount only. Side mount is .31" higher. Allow 3" bump clearance from full load.

Start Angle	Bracket Profile	No Load		Full Load		Shock Load	
		H	L	H	L	H	L
45° Down	High	7.18	4.24	5.24	5.54	4.24	5.83
32° Down	High	6.12	5.09	3.93	5.92	2.94	5.84
22.5° Down	High	5.24	5.54	2.94	6.00	1.90	5.91
10° Down	High	3.98	5.91	1.64	5.86	0.64	5.54
0°	High	2.94	6.00	0.64	5.54	-0.28	5.06
10° Up	High	1.90	5.91	-0.28	5.06	-0.11	4.42
22.5° Up	High	0.64	5.54	-1.30	4.24	-1.97	3.44



Note: Positive numbers in the H column indicate the spindle is BELOW the top of the bracket. Conversely, negative numbers are ABOVE the top of the bracket.

Overhang Per Side

Spindle	Min.	Max.	Brake
#13D	12.25"	17.20"	12¼" x 4"
#13G one-piece	10.11"	17.20"	12¼" x 3¾"
#13G two-piece	11.35"	17.20"	12¼" x 3¾"

Note: Dual wheel not available for #13G one-piece. One-piece hub/drum is not interchangeable with the two-piece hub & drum.



Full Load Dimensions

Dimensions are for high profile, top mount only. Side mount is .31" higher. Allow 3" bump clearance from full load.

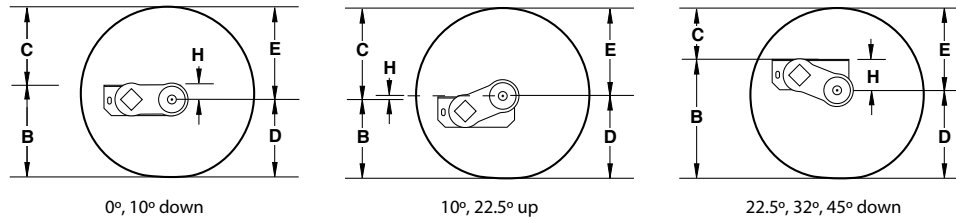

Start Angle

Tire	* **		45° Down				32° Down				22.5° Down				10° Down				0°				10° Up				22.5° Up			
	D	E	H	B	C	H	B	C	H	B	C	H	B	C	H	B	C	H	B	C	H	B	C	H	B	C				
LT235/85R16	14.3	15.4	5.2	19.5	10.2	3.9	18.2	11.4	2.9	17.2	12.5	1.6	15.9	13.8	.6	14.9	14.8	-0.3	13.7	15.6	-1.3	13.0	16.7							
215/75R17.5	14.0	15.3	5.2	19.2	10.1	3.9	17.9	11.3	2.9	16.9	12.4	1.6	15.6	13.7	.6	14.6	14.7	-0.3	13.7	15.6	-1.3	12.7	16.6							
235/75R17.5	14.3	15.7	5.2	19.5	10.5	3.9	18.2	11.7	2.9	17.2	12.8	1.6	15.9	14.1	.6	14.9	15.1	-0.3	14.0	16.0	-1.3	13.0	17.0							
9R17.5HC	15.4	17.1	5.2	20.6	11.9	3.9	19.3	13.1	2.9	18.3	14.2	1.6	17.0	15.5	.6	16.0	16.5	-0.3	15.1	17.4	-1.3	14.1	18.4							
10R17.5HC	15.6	18.0	5.2	20.8	12.8	3.9	19.5	14.0	2.9	18.5	15.1	1.6	17.2	16.4	.6	16.2	17.4	-0.3	15.3	18.3	-1.3	14.3	19.3							

Columns D and E are dimensional examples only:

* D – Static Loaded Radius

** E – Inflated Radius

#13D & #13G Bracket Dimensions

A	1.22
B	3.63
C	10.56
D	10.56
E	13.00
F	5.50
G	2.50
H	2.25
I	7.26
J	1.00
K	1.00
Bolt Size	5/8" bolt
Tube Size	3.88

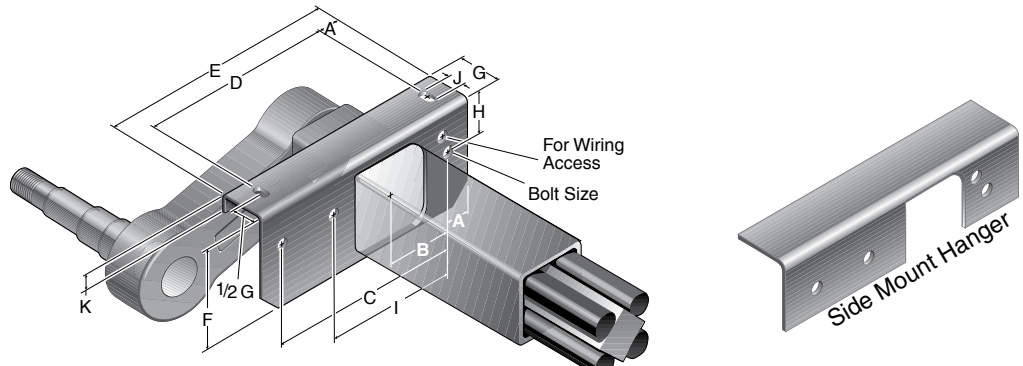

High Profile



Articulation Dimensions

Dimensions are for #14 bracket. Allow 3" bump clearance from full load.

Start Angle	Bracket Profile	No Load		Full Load		Shock Load	
		H	L	H	L	H	L
45° Down	High	7.68	4.24	5.74	5.54	4.74	5.83
32° Down	High	6.62	5.09	4.43	5.92	3.44	5.84
22.5° Down	High	5.74	5.54	3.44	6.00	2.40	5.91
10° Down	High	4.48	5.91	2.14	5.86	1.14	5.54
0°	High	3.44	6.00	1.14	5.54	0.22	5.06
10° Up	High	2.40	5.91	0.22	5.06	0.39	4.42
22.5° Up	High	1.14	5.54	-0.80	4.24	-1.47	3.44

Overhang Per Side

Spindle	Min.	Brake
#14	12.75"	12¼" x 5"
#14T	9.89"	12¼" x 3⅜"
#14	9.19"	Disc

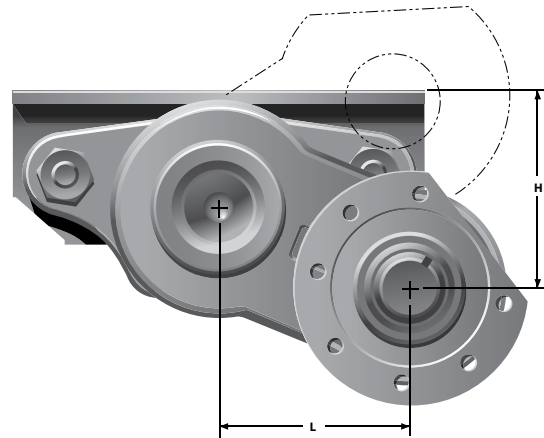

Note: Positive numbers in the H column indicate the spindle is BELOW the top of the bracket. Conversely, negative numbers are ABOVE the top of the bracket.

Note: One-piece hub/drum is not interchangeable with the two-piece hub & drum.



Full Load Dimensions

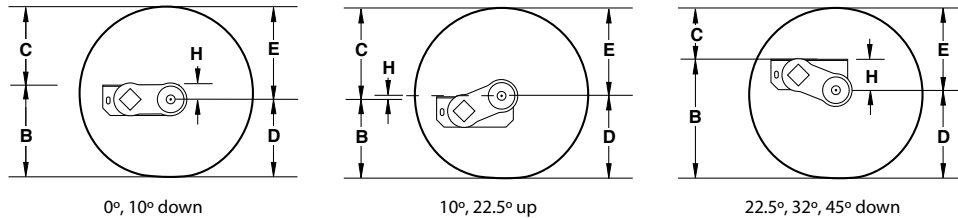

Start Angle

Tire	* **		45° Down			32° Down			22.5° Down			10° Down			0°			10° Up			22.5° Up		
	D	E	H	B	C	H	B	C	H	B	C	H	B	C	H	B	C	H	B	C	H	B	C
LT235/85R16	14.3	15.4	5.7	20.0	9.70	4.4	18.7	11.0	3.4	17.7	12.0	2.1	16.4	13.3	1.1	15.4	14.3	.2	14.5	15.2	-0.8	13.5	16.2
215/75R17.5	14.0	15.3	5.7	19.7	9.60	4.4	18.4	10.9	3.4	17.4	11.9	2.1	16.1	13.2	1.1	15.1	14.2	.1	14.2	15.1	-0.8	13.2	16.1
235/75R17.5	14.3	15.7	5.7	20.0	10.0	4.4	18.7	11.3	3.4	17.7	12.3	2.1	16.4	13.6	1.1	15.4	14.6	.2	14.5	15.5	-0.8	13.5	16.5
9R17.5HC	15.4	17.1	5.7	21.1	11.4	4.4	19.8	12.7	3.4	18.8	13.7	2.1	17.5	15.0	1.1	16.5	16.0	.2	15.6	16.9	-0.8	14.6	17.9
10R17.5HC	15.6	18.0	5.7	21.3	12.3	4.4	20.0	13.6	3.4	19.0	14.6	2.1	17.7	15.9	1.1	16.7	16.9	.2	15.8	17.8	-0.8	14.8	18.8

Columns D and E are dimensional examples only:

* D – Static Loaded Radius

** E – Inflated Radius

#14 Bracket Dimensions

A	4.50
B	9.00
C	12.00
D	4.50
E	2.44
F	2.50
Bolt Size	¾" bolt
Tube Size	4.25

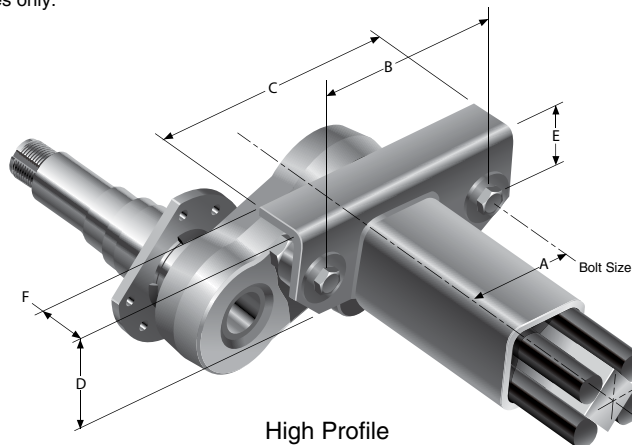

High Profile